

# STATIC ANALYSIS of a SINGLE STAGE HYDRAULIC CYLINDER.

V.GómezRodríguez<sup>#1</sup>, Juan José CabelloEras<sup>#2</sup>, Hernán HernándezHerrera<sup>#3</sup>, Rafael GoytisolóEspinoza<sup>#4</sup>.

<sup>#1</sup>Bolivariano Technological Institute of Technology. Guayaquil. Ecuador.  
<sup>1</sup>vgomez@bolivariano.edu.ec

<sup>#2</sup>Faculty of Engineering, Universidad de la Costa. Barranquilla, Colombia.  
<sup>2</sup>jcabello2@cuc.edu.co

<sup>#3</sup>Faculty of Engineering, Universidad de la Costa. Barranquilla, Colombia.  
<sup>3</sup>hhernand16@cuc.edu.co

<sup>#4</sup> Faculty of Engineering, Universidad de Cienfuegos. Cienfuegos, Cuba.  
<sup>4</sup>ragoyti@ucf.edu.cu

**Abstract-** In this study the static analysis of a single stage hydraulic cylinder is considered. A complete theoretical model is developed that allows the consideration of all the factors that affect the statics of a hydraulic cylinder in its action as a compression member. The scheme is based on the classical Euler-Bernoulli beam theory, and makes detailed account of all the loadings present, and of the various types of boundary conditions.

**Keywords-** Scheme of analysis, Hydraulic cylinder, Single stage, New factors

## I. INTRODUCTION

Hydraulic cylinders are compression members consisting of parts having different rigidity. In the simplest case there are two parts (Fig. 1), but in more complicated cases, such as telescopic cylinders, there are several parts [1],[2], [3]. A number of different combinations of support conditions at the ends are encountered in these problems. In the simplest case there are pinned supports at both ends, while in other cases the supports may be pinned-fixed, doubly-fixed, or fixed-free. In exceptional conditions, hydraulic cylinders operate solely in the vertical condition, but more commonly they operate in an inclined position or in a completely horizontal position. In these latter positions the self-weight of the cylinder and the hydraulic fluid often provide a transverse load that increases the eccentricity of axial loads. Further factors requiring consideration are the sliding joint between the rod and cylinder, and the looseness in the joints, implying elasticity in the connections or supports. The components forming the hydraulic cylinder have step-variations in their stiffness, and thus the equation governing the deflection is discontinuous over the domain, which complicates the analysis.

In the technical literature a number of approaches for the analysis of compression members have been presented [4], [5], [6], [7], but none has completely addressed the full details that are encountered with practical hydraulic cylinders. Articles and the study of the various catalogs provided by suppliers of hydraulic cylinders indicate that some details related to hydraulic cylinders are not taken into consideration, and that approximate approaches of analysis are applied, which may in cases lead to non-conservative results [8], [9], [10]. The industry produces a variety of hydraulic cylinder products, and generally carries out complete designs for its products. Nevertheless, there is no available methodology, appropriate for comprehensive analysis of hydraulic cylinders, which accounts for both transverse and axial loads. Thus a comprehensive scheme of calculation is required which considers completely the various loading and support conditions that may arise, and which ultimately leads to a safe product having economical dimensions.

### A. Stability analysis of compression members.

The classical method of stability analysis of a compression member is described by Timoshenko [11]. Other methods exist which offer a more detailed consideration of the problem [12], [13], [14]. These methods include the classical Euler-Bernoulli method based on an approximate differential equation for the elastic bending of a beam, methods based on semi-empirical formulas, the method of the  $\phi$ -coefficient for the reduction of the admissible stress, energy methods, the method of the parameters of the origin, the method of the integration of the differential equation, the finite element method, the secant formula for the case of columns with eccentric load, and the method of limit loads for the case of the loss of stability due to simultaneous longitudinal and transverse bending. Most of these methods cover only compression members having constant rigidity, and thus cannot be applied directly to hydraulic cylinders. It has been shown that the method of parameters of the origin to determine the critical load, while permitting the analysis of structures with variable rigidity, is excessively complicated in solution if all the factors affecting the problem are to be considered [15].

### B. Static analysis of hydraulic cylinders.

With the development of computer-aided methods, and the availability of new mathematical approaches, attempts have been made to overcome difficulties posed by equations governing domains containing step-variations in properties [16],[17]. The model proposed by [15] considered the cylinder as a beam with step variations in rigidity, subjected to perfect loading (no eccentricities), and lacking of initial curvature. In this approach the possible influence of a loose fit in the joints is not considered, nor the effect of self-weight in the case when the cylinder adopts a position at an angle to the vertical.

In paper [18] analyzed the influence of the extension length on loads distribution through sliding contacts along the boom. In another work [19], a method is used which permits determination of stability characteristics for cylinder of any number of stages. The results obtained in that work are superior to results obtained in other works. A deficiency in previous methods stems from the fact that the self-weight of the cylinder is not considered, despite the fact that it has a substantial influence on the deformation of the rod in an articulated system. The influence is due to the bending caused by the self-weight, and to the moment causing a sagging equal only to the deformation produced by the loose fit of the sliding joint in each stage. In other work [20] the bending is determined without considering that the rod is subjected to a combination of transverse and longitudinal flexure. In further studies empirical methods have also been presented to determine the stability of hydraulic cylinders, and the finite element method has been used, in which the cylinder is modeled as a column with a cross-section that varies in the longitudinal direction.

## II. THEORY.

### C. Modeling of the system

In the scheme of analysis presented in this study the following factors are taken into account, which generally have not been considered in previous studies:

- Loose fit existing between the piston – body and rod – and the axle box.
- Self-weight of the cylinder and the hydraulic fluid.
- Moment caused by the friction in pinned joints.
- A general treatment of the supports: fixed, pinned, elastic, etc.
- Positioning of a support along the length of the cylinder.
- Inclination of the cylinder.
- Eccentricity of the axial load at either end.
- Variation in the slope produced by the elasticity of the axle box and seals.
- The details of the construction of the rod: solid or hollow, with or without internal pressure.

### D. Scheme of the analysis.

The scheme of analysis proposed for a cylinder of single stage is shown in Figs. 1a and 1b.

Where:

$W_{CULATA}$ ,  $L_{CULATA}$  – weight and length of the cylinder head.

$W_{LH}$ ,  $L_{CP}$  – weight of the hydraulic fluid and length of fluid column from the head to the front face of the piston.

$W_C$ ,  $L_C$  – weight and length of the cylindrical tube.

$W_V$ ,  $L_V$  – weight and length of the rod.

$W_{cp}$ ,  $W_{bg}$ ,  $W_{tu}$  – weight of the head of the piston, the guiding axle and the bolts of the attachment.

$W_{OREJA}$ ,  $L_{OREJA}$  – weight and length of the ring connection.

$L_p$  – distance from the head to the intermediate support.

It is considered that the two components of the model, CA and CB (Fig. 1b), have a rigidity equal to that of a cylindrical tube (sleeve)  $R_1$  and that of a rod, respectively  $R_2$ . The components are subject to a uniformly distributed loading equal to the combined sum of the various components and the hydraulic fluid, divided by the length. The transition point C is the point where the axis of the cylindrical tube and the axis of the rod intersect, when the system deforms due to the action of applied loads. The weight  $W$  of the sliding connection between the cylindrical body and the rod is considered as a load concentrated at the transition point C, as indicated in Fig. 1b. The weights of the axle box and the piston head are included in the concentrated load  $W$  acting at the transition point C.

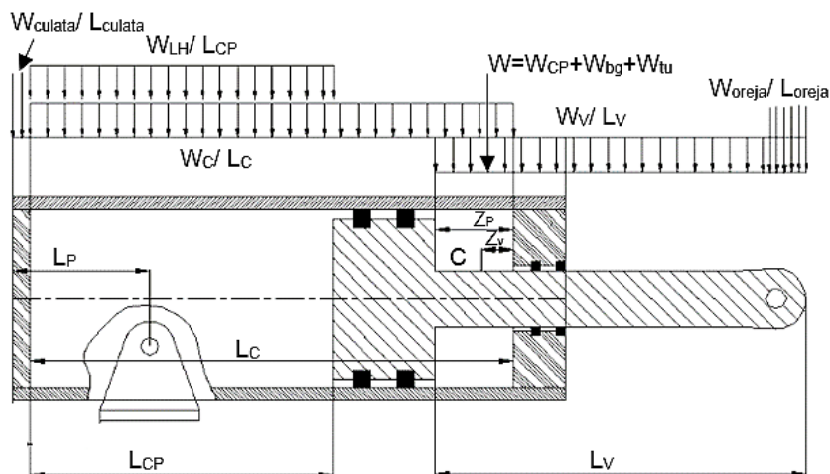

Fig. 1a. System of loads for a practical hydraulic cylinder.

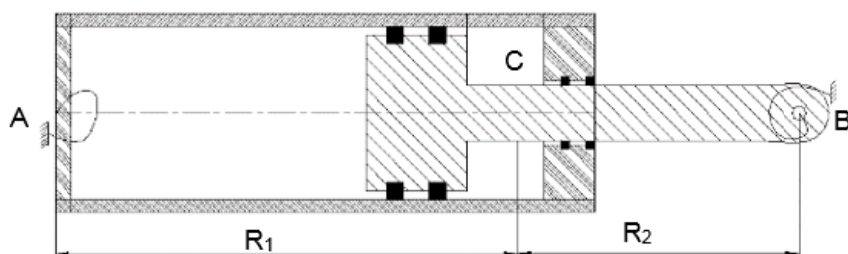

Fig. 1b. Rigidity of the two components.

In Fig. 2 there is presented justification for the consideration of these distributed loads as a concentrated load at point C, where it is clear that the difference caused in the flexural moment is small.

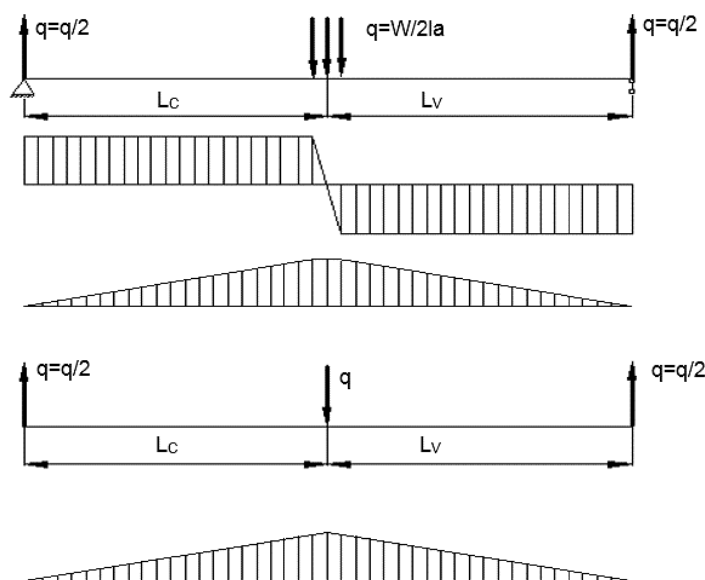

Fig. 2. Comparison of moments for idealizations of the load at point C.

The moment with respect to point C, produced by the weight of the piston head, the axle box, and the supported parts distributed due to the weight of the cylinder and the rod were not considered due to their negligible effect see Fig. 3. For the case of a cylinder with an intermediate support, the moment produced by the weight of the cantilever part was applied at the position of support of the cylinder. The axle box and the seal were considered as elastic elements, and replaced by linear springs.

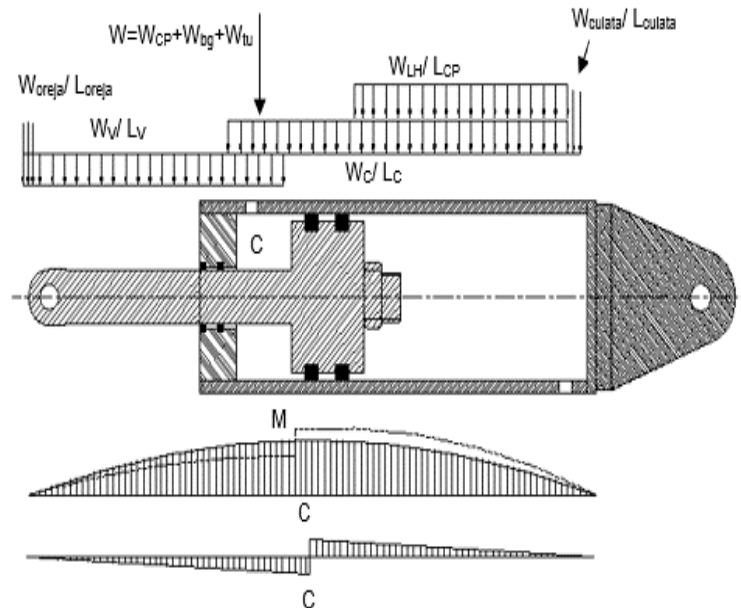

Fig. 3. Symbolic plot representing the effect of the moment M produced by the concentrated load W at point C.

*E. Details of the static analysis of a single stage cylinder.*

Expressions may be written for the moment, slope, and displacement valid at every point along the length of the cylinder. In Fig. 4 is shown the configuration of a single stage cylinder, including the applied forces and reactions. In this diagram:

P – axial load on the cylinder.

L – length between supports of the cylinder.

ec, ev – eccentricities of the axial load in the cylinder and rod.

$\beta_c, \beta_v$  – angular deviations of the axis of the cylinder and the axis of the rod with respect to the supports.

$k_c, k_v$  – stiffnesses of the rotational springs in the pins of the supports of the cylinder and rod respectively (angular rigidity of the supports).

$f_c, f_v$  – coefficients of friction in the pins of the supports of the cylinder and rod respectively.

$R_c$  – lateral reaction of the support of the cylinder produced by the self-weight of the system.

$R_v$  – lateral reaction of the support of the rod produced by the self-weight of the system.

$$M_p = \frac{w_1 \cdot L^2}{2} \text{ moment produced by the self-weight of the cantilever part of the body}$$

W – concentrated force at point C due to the weight of the piston, the axle box, and of the parts of the cylinder and the rod in the sliding joint.

$w_1$  – weight per unit length of the cylinder and the hydraulic fluid.

$w_2$  – weight per unit length of the rod.

In Fig. 4 are shown the reactions produced by the difference in eccentricities between the support of the rod and the support of the body, the reaction produced by the moment of friction in the pinned joints, the reaction produced due to the rigidity in rotation of the fixed ends, and the reactions produced by the self-weight of the system: the reaction produced by the cantilever part of the cylinder in cases containing intermediate supports, the reaction produced by the weight of the cylinder tube, the rod and the hydraulic fluid, and the reaction produced by the concentrated force at the point C.

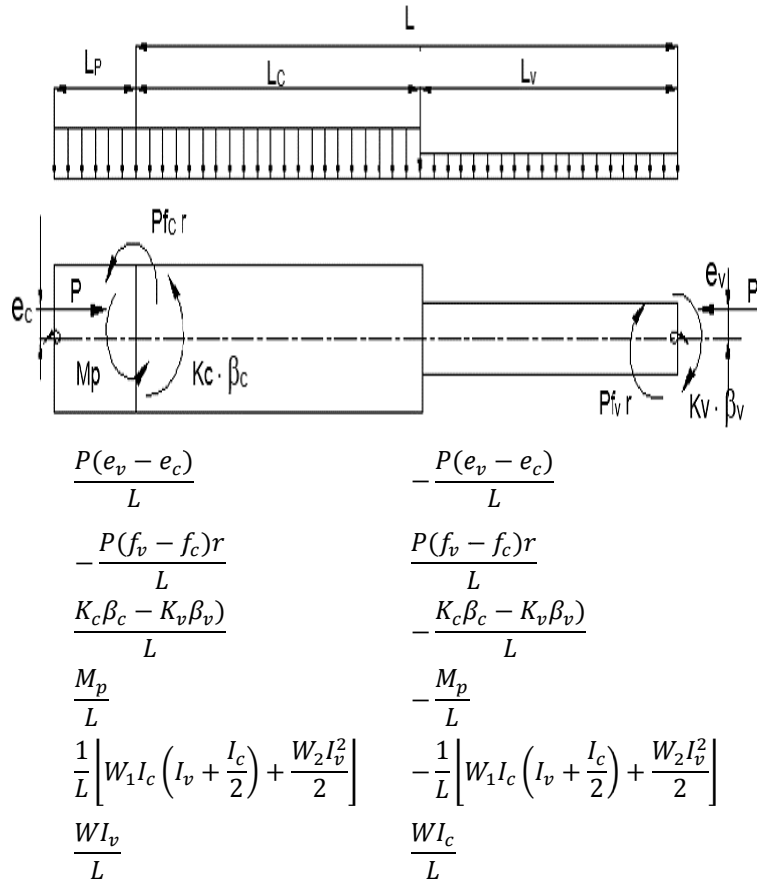

Fig. 4. External forces and reactions in a single stage hydraulic cylinder.

In this analysis, the differential equations for the deflection are written for the tube and rod parts of the hydraulic cylinder. These differential equations are enforced together with the boundary conditions, and the conditions of compatibility to obtain the equations governing the bending of the member. The geometric details for a single stage hydraulic cylinder, in three possible positions, are shown in Fig. 5: completely straight, with an initial slope  $\beta'$  but without any axial load, and with a slope of  $\beta$  which increases with an increase in the load. The system passes through these three states when it is subject to an axial load at the end. It is clear that the angular deviation at any point of the system is, from one part, owing to the presence of the slope, and from the other part, owing to the flexure of the body of the tube and the rod.

In Fig. 5 the portion of the deviation from the absolute straight position to the position indicated by the dotted lines is due to the slope, and the portion of the dotted lines in the deformed position is due to the flexural moment of the system. The differential equations are written for the overall effect.

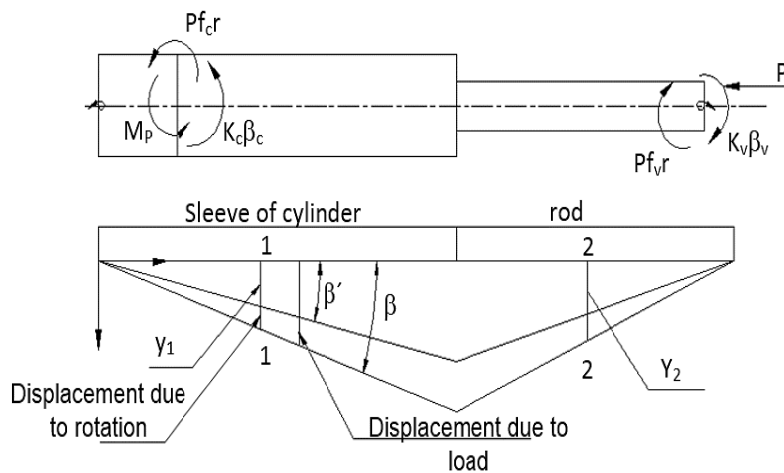

Fig. 5. Tangent displacement lines in a typical hydraulic cylinder

### III. EQUATIONS FOR THE CALCULATION SCHEME.

For an arbitrary section of the tube part, for example the section 1-1 of Fig. 5, the flexural moment that produces the curvature is obtained by taking the product of the flexural rigidity with the second derivative of the displacement for this part, namely:

$$M_1 = -E_1 \cdot I_1 \frac{d^2 \cdot y_1}{dz^2} \quad (1)$$

The flexural moment in this section produced by the external loads and the reactions is:

$$M_1 = \frac{P(e_v - e_c)}{L} z - \frac{P(f_v - f_c)}{L} z + \frac{(k_c \beta_c - k_v \beta_v)}{L} + R_c z - M_p - P \cdot f_c - k_c \cdot \beta_c - \frac{w_1}{2} z^2 + P(e_c + y_1) \quad (2)$$

Where:

$y_1$  – displacement at a distance  $z$  in the cylinder, measured with respect to the left support.

For equilibrium the internal and external moments must be equal. Thus combining equations (1) and (2) one obtains.

$$\frac{d^2 y_1}{dz^2} + k_1^2 y_1 = k_1^2 \left[ -\frac{(e_v - e_c)}{L} z + \frac{(f_v - f_c)}{L} z - \frac{(k_c \beta_c - k_v \beta_v)}{PL} z - \frac{R_c}{P} z + \frac{M_p}{P} + f_c + \frac{k_c \beta_c}{L} - e_c + \frac{w_1}{2P} z^2 \right] \quad (3)$$

Where:

$$K_1^2 = \frac{P}{E_1 I_1}$$

An analysis is next carried for the rod part of the structural member (section 2-2, Fig. 5), for which one obtains:

$$\frac{d^2 y_2}{dz^2} + k_2^2 y_2 = k_2^2 \left[ -\frac{(e_v - e_c)}{L} (L - z) + \frac{(f_v - f_c)}{L} (L - z) - \frac{(k_c \beta_c - k_v \beta_v)}{PL} (L - z) - \frac{R_v}{P} (L - z) + f_v + \frac{k_v \beta_v}{P} - e_v + \frac{w_2}{2P} (L - z)^2 \right] \quad (4)$$

Where:

$$K_2^2 = \frac{P}{E_2 I_2}$$

The differential equations (3) and (4) describe the behavior of the displacements in the tube and the rod parts of a hydraulic cylinder carrying an axial load. The boundary conditions, and the continuity conditions to be satisfied in solving these equations are:

$$\begin{aligned} z = 0 & & y_1 &= 0 \\ z = L & & y_2 &= 0 \\ z = l_c & & y_1 &= y_2 \\ z = l_c & & \frac{dy_1}{dz} - \beta &= \frac{dy_2}{dz} \end{aligned}$$

The solution for equations (3) and (4) are obtained as:

$$y_1 = C_1 \cos(K_1 \cdot z) + D_1 \sin(K_1 \cdot z) - \frac{(e_v - e_c)}{L} z + \frac{(f_v - f_c)}{L} z - \frac{(k_c \beta_c - k_v \beta_v)}{PL} z - \frac{R_c}{P} z + T_1 + \frac{k_c \beta_c}{P} + \frac{w_1}{2P} z^2 \quad (5)$$

$$(0 \leq z \leq l_c)$$

and

$$y_2 = C_2 \cos(K_2 \cdot z) + D_2 \sin(K_2 \cdot z) - \frac{(e_v - e_c)}{L} (L - z) + \frac{(f_v - f_c)}{L} (L - z) - \frac{(k_c \beta_c - k_v \beta_v)}{PL} (L - z) - \frac{R_v}{P} (L - z) + T_2 + \frac{k_v \beta_v}{P} + \frac{w_2}{2P} (L - z)^2 \quad (6)$$

$$(l_c \leq z \leq L)$$

Where:

$$T_1 = \frac{M_p}{P} + f_c - e_c - \frac{W_1}{PK_1^2} \quad (7)$$

$$T_2 = f_v - e_v - \frac{W_2}{PK_2^2} \quad (8)$$

Where  $C_1, C_2, D_1,$  and  $D_2$  are constants to be determined from the conditions (5).

Application of the equations (5) leads to the following values for the constants  $C_1$  and  $C_2$ .

$$C_1 = -T_1 - \frac{K_c \beta_c}{P} \quad (9)$$

$$C_2 = \left[ -D_2 \sin(K_2 L) - T_2 - \frac{K_v \beta_v}{P} \right] \frac{1}{\cos(K_2 L)} \quad (10)$$

With the application of the continuity conditions at the sliding joint, i.e. at  $z=l_c$  and substituting the values of  $C_1$  and  $C_2$  from equations (10) and (11) one obtains the relation.

$$D_1 \sin(K_1 I_c) + D_2 \frac{\sin(K_2 I_v)}{\cos(K_2 L)} = \left[ T_1 + \frac{K_c \beta_c}{P} \right] \cos(K_1 I_c) - \left[ T_2 + \frac{K_v \beta_v}{P} \right] \left[ \frac{\cos(K_2 I_c)}{\cos(K_2 L)} \right] - T_3 \quad (11)$$

Where:

$$T_3 = \frac{W_2}{PK_2^2} - \frac{w_1}{PK_1^2} \quad (12)$$

The equations for the slope are obtained as the first derivative of the displacements (6) and (7) as:

$$\frac{dy_1}{dz} = -C_1 K_1 \sin(K_1 \cdot z) + D_1 K_1 \cos(K_1 \cdot z) - \frac{(e_v - e_c)}{L} + \frac{(f_v - f_c)}{L} - \frac{(k_c \beta_c - k_v \beta_v)}{PL} - \frac{R_c}{P} + \frac{w_1}{2P} z \quad (13)$$

$(0 \leq z \leq l_c)$

$$\frac{dy_2}{dz} = -C_2 K_2 \sin(K_2 \cdot z) + D_2 K_2 \cos(K_2 \cdot z) - \frac{(e_v - e_c)}{L} + \frac{(f_v - f_c)}{L} - \frac{(k_c \beta_c - k_v \beta_v)}{PL} + \frac{R_v}{P} - \frac{w_2}{2P} (L - z) \quad (14)$$

Enforcing the continuity conditions at the sliding joint, and substituting the values of  $C_1$  and  $C_2$  from equations (10) and (11), one obtains:

$$D_1 K_1 \sin(K_1 I_c) - D_2 K_2 \frac{\cos(K_2 I_v)}{\cos(K_2 L)} = \left( -T_1 - \frac{K_c \beta_c}{P} \right) K_1 \sin(K_1 I_c) + \left[ T_2 + \frac{K_v \beta_v}{P} \right] \left[ \frac{K_2 \sin(K_2 I_c)}{\cos(K_2 L)} \right] + \frac{W}{P} + \beta \quad (15)$$

Where:

$$W = R_c + R_v - w_1 I_c - W_2 I_v$$

Solving simultaneously the equation (12) and (16) one obtains:

$$D_1 = \frac{1}{Q} \left\{ \left[ \frac{K_c \beta_c}{P} + T_1 \right] \left[ \frac{(K_2 - K_1 \tan(K_1 I_c) \tan(K_2 I_v))}{\tan(K_1 I_c) \tan(K_2 I_v)} \right] - \left[ T_2 + \frac{K_v \beta_v}{P} \right] \left[ \frac{K_2}{\sin(K_1 I_c) \sin(K_2 I_v)} \right] - \frac{T_3 K_2}{\sin(K_1 I_c) \sin(K_2 I_v)} + \left[ \beta + \frac{W}{P} \right] \frac{1}{\sin(K_1 I_c)} \right\} \quad (16)$$

$$D_2 = \frac{1}{Q} \left\{ \left[ \frac{K_c \beta_c}{P} + T_1 \right] \left[ \frac{K_1 \cos(K_2 L)}{\sin(K_1 I_c) \sin(K_2 I_v)} \right] - \left[ T_2 + \frac{K_v \beta_v}{P} \right] \left[ \frac{K_2 \tan(K_1 I_c) \tan(K_2 I_c) + K_1}{\tan(K_1 I_c) \sin(K_2 I_v)} \right] - \frac{T_3 K_1 \cos(K_2 L)}{\tan(K_1 I_c) \sin(K_2 I_v)} - \left[ \beta + \frac{W}{P} \right] \left[ \frac{\cos(K_2 L)}{\sin(K_2 I_v)} \right] \right\} \quad (17)$$

Where:

$$Q = \frac{K_1}{\tan(K_1 I_c)} + \frac{K_2}{\tan(K_2 I_v)} \quad (18)$$

The values of the constants  $C_1, C_2, D_1$  and  $D_2$  in the displacement equations (6) and (7) and the equations for the slope (14) and (15) are obtained from the relations (10), (11), (17) and (18), respectively.

The slope  $\beta$  is evaluated using a procedure proposed by the authors. The other two unknown values,  $\beta_c$  and  $\beta_v$ , which appear in the equations of displacement and slope and in the equations to determine  $C_1, C_2, D_1$  and  $D_2$  are found by enforcing the following conditions of compatibility.

$$Z = 0 \quad \frac{dy_1}{dz} = \beta_c$$

And

$$Z = l \quad \frac{dy_2}{dz} = \beta_v$$

On combining the equations (10), (11), (14), (15),(17),(18), and (20) one obtains two relations which have theform:

$$\beta_c A_{11} + \beta_v A_{12} = B_1 \tag{19}$$

And

$$\beta_c A_{21} + \beta_v A_{22} = B_2 \tag{20}$$

Where:

$$A_{11} = 1 - \frac{K_c K_1 (K_2 - K_1 \tan(K_1 I_c) \tan(K_2 I_v))}{P [K_1 \tan(K_2 I_v) + K_2 \tan(K_1 I_c)]} + \frac{K_c}{PL} \tag{21}$$

$$A_{12} = \frac{K_v K_1 K_2}{PK_1 \tan(K_2 I_v) + K_2 \tan(K_1 I_c) \cos(K_2 I_v) \cos(K_1 I_c)} - \frac{K_v}{PL} \tag{22}$$

$$B_1 = \frac{K_1}{Q} \left\{ T_1 \left[ \frac{[K_2 - K_1 \tan(K_1 I_c) \tan(K_2 I_v)]}{\tan(K_1 I_c) \tan(K_2 I_v)} \right] - \frac{T_2 K_2}{\sin(K_1 I_c) \tan(K_2 I_v)} - \frac{T_3 K_2}{\sin(K_1 I_c) \tan(K_2 I_v)} \right. \\ \left. + \left( \beta + \frac{W}{P} \right) \frac{1}{\sin(K_1 I_c)} - \frac{(e_v - e_c)}{L} + \frac{(f_v - f_c)}{L} - \frac{R_c}{P} \right\} \tag{23}$$

$$A_{21} = -\frac{K_c}{P} \left[ \frac{[K_1 K_2]}{[K_1 \tan(K_2 I_v) + K_2 \tan(K_1 I_c)]} \right] \frac{1}{\cos(K_1 I_c) \cos(K_2 I_v)} + \frac{K_c}{PL} \tag{24}$$

$$A_{22} = \left[ 1 + \frac{K_v [K_2 \tan(K_1 I_c) \tan(K_2 I_c) + K_1]}{P [K_1 \tan(K_2 I_v) + K_2 \tan(K_1 I_c)]} \right] \cdot \frac{K_2 \cos(K_2 I_c)}{\cos(K_2 I_v) \cos(K_2 L)} - \frac{K_v K_2 \sin(K_2 L)}{P \cos(K_2 L)} - \frac{K_v}{PL} \tag{25}$$

$$B_2 = \frac{K_2}{Q} \left\{ \left[ \frac{T_1 K_1}{\sin(K_1 I_c) \sin(K_2 I_v)} \right] - T_2 \left[ \frac{(K_2 \tan(K_1 I_c) + \tan(K_2 I_c)) + K_1 \cos(K_2 I_c)}{\tan(K_1 I_c) \sin(K_2 I_v) \cos(K_2 L)} \right] \right. \\ \left. - \frac{T_3 K_1}{\tan(K_1 I_c) \sin(K_2 I_v)} - \left( \beta + \frac{W}{P} \right) \frac{1}{\sin(K_2 I_v)} + T_2 K_2 \tan(K_2 L) - \frac{(e_v - e_c)}{L} + \frac{(f_v - f_c)}{L} - \frac{R_v}{P} \right\} \tag{26}$$

Solving simultaneously the equations (21) y (22) oneobtains:

$$\beta_c = \frac{B_1 A_{22} - A_{12} B_2}{A_{11} A_{22} - A_{12} A_{21}}$$

And

$$\beta_c = \frac{B_2 A_{11} - A_{21} B_1}{A_{11} A_{22} - A_{12} A_{21}}$$

With the equations (10), (11), (17), (18), (29), and (30) one can determine the unknowns C<sub>1</sub>, C<sub>2</sub>, D<sub>1</sub>, D<sub>2</sub>β<sub>c</sub>, and β<sub>v</sub>,respectively, in the equations of the displacement (6) and (7), and in the equations for the slope (14) and (15).

The equation for the flexural moment for the tube part of the body is found using equations (12), and similarly the flexural moment in the rod part of the body is found using the equation:

$$M_2 = -\frac{P(e_v - e_c)}{L}(L - z) + \frac{P(f_v - f_c)}{L}(L - z) - \frac{[k_c \beta_c - k_v \beta_v]}{L}(L - z) + R_v(L - z) - P f_v - K_v \beta_v \\ - \frac{W_2}{2}(L - z)^2 + P(e_v + y_2) \tag{27}$$

#### IV. CONCLUSIONS.

An approach has been presented for the static analysis of a hydraulic cylinder of a single stage. The approach is comprehensive, and permits consideration of a number of factors, which have not been accounted for in previous studies.

The equations obtained allow to improve the design of the hydraulic cylinders providing economical designs with appropriate safety factors.



## REFERENCES.

- [1] G. Seebacher, H. Winkler, "Evaluating flexibility in discrete manufacturing based on performance and efficiency", *Int. J. Production Economics*, vol. 153, pp. 340-351, Jul. 2014.
- [2] A. Trajka, "Dynamics of telescopic cranes with flexible structural components", *International Journal of Mechanical Sciences*, vol. 88, pp. 162-174, Nov. 2014.
- [3] B. Posiadala, D. Cekus, "Vibration model and analysis of three-member telescopic boom with hydraulic cylinder for its radius change", *International Journal of Bifurcation and Chaos*, vol. 21, pp. 2883-2892, Oct. 2011.
- [4] C. H. Yoo, C. R. Siegel, "Column loadings on telescopic power cylinders", *Computers & structures*, Vol. 22, No 3, pp. 245-251, Feb. 2003.
- [5] S. Baragetti, A. Terranova, "Bending behaviour of double-acting hydraulic actuator's". *Proc. of the Institution of Mechanical Engineers, Part C: Journal of Mechanical Engineering Science*, vol. 215 No 5, pp. 607-619, May. 2001.
- [6] T. Nguyen, K. H. Tan, "Thermal-induced restraint forces in reinforced concrete columns subjected to eccentric loads". *Fire Safety Journal*, vol. 69, pp.136-146, Oct. 2014.
- [7] M. R. Sheidai, R. Bahrminejad, "Evaluation of compression member buckling and post-buckling behavior using artificial neural network". *Journal of Constructional Steel Research*, vol. 70, pp. 71-77. Mar. 2012.
- [8] R. Mijailović, "Modelling the dynamic behaviour of the truck-crane", *Journal Transport*. vol. 26 No 4, pp. 410-417, Jan. 2012.
- [9] N. Uchiyama, "Robust control of rotary crane by partial-state feedback with integrator", *Mechatronics*, vol. 19, pp.1294-1302, Dec. 2009.
- [10] V. Gómez, J. Cabello, "Low carbon steel evaluation for oleohydraulic cylinders manufacturing". *Mechanical Engineering*, vol. 6, pp. 7-11, Jan. 2003.
- [11] S.P. Timoshenko, "History of Strength of Materials", New York: Dover, 1983.
- [12] W.P. Dawkins, S.K. Iyengar, "Stress analysis of hydraulic cylinders", in *Proc. National Conference on Fluid Power*, Chicago, vol. 29. 1975.
- [13] S. Uzny, "Free vibrations and stability of hydraulic cylinder fixed elastically on both ends", in *Proc. Appl. Math. Mech*, vol. 9, No. 1, pp. 303-304. Mar. 2010.
- [14] L. Tomski, S. Uzny, "A hydraulic cylinder subjected to Euler's load in aspect of the stability and free vibrations taking into account discrete elastic elements". *Archives of civil and mechanical engineering*, vol. 11, No 3, pp. 769-785, May. 2011.
- [15] M. Torres del Toro, "Application of Differential Equations to the Analysis of the Stability of Telescopic Hydraulic Cylinders", M. Eng. thesis, University of Cienfuegos, Nov. 1999.
- [16] O. Navarro, "Stability of Telescopic Hydraulic Cylinders", M. Eng. thesis, University of Cienfuegos, Sep. 2001.
- [17] M. Balbis, R. Goytisoló, H. Hernández, J. Cabello, "Stress in butt welded joints of open profiles under torsion" *Ingeniare*, vol. 23, pp. 638-646, Nov. 2015.
- [18] N. Kumar, M. Parvez, "Force distribution on telescopic boom of crane". *Int. J. Mech. Eng. Robot. Res.* vol.1, pp. 96-104, Jul. 2012.
- [19] J. Cabello, "Methodology for the design of hydraulic cylinders". *Construcción de maquinarias*, vol. 1.No. 3, Nov. 1995.
- [20] H.G. Puhl, "Static analysis and experimentation of elastic hydraulic cylinders", *Forschungsheft*, vol.34, No. 6, pp. 237-244. Jun. 1973.

## AUTHOR PROFILE

Victor Gómez Rodríguez is working as professor at Bolivarian Technological Institute of Technology. His interest areas are applied mechanics.

Juan Jose Cabello Eras is working as professor at Universidad de la Costa. His interest areas are applied mechanics and energy efficiency.

Hernan Hernández Herrera is working as professor at Universidad de la Costa. His interest areas are applied mechanics and energy efficiency.

Rafael Goytisoló Espinosa is working as professor at Universidad de Cienfuegos. His interest areas are applied mechanics.